

ELECTRIC STRIKES - 125100 SERIES

ELECTRIC STRIKES

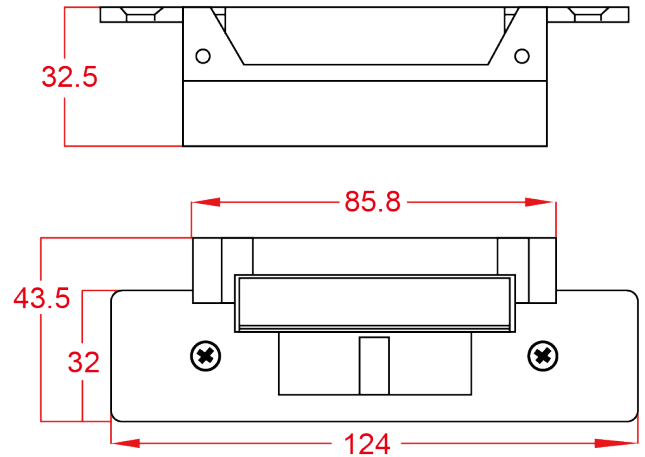

- 125100 / 125101 / 125102 : 124L*32W*32.5H mm



▼ ORDERING INFORMATION

12510X

- 0 - Basic
- 1 - Latch sensor
- 2 - Latch sensor & Keeper sensor

EXAMPLE :

- 125100 : Stainless steel faceplate fail secure basic
- 125101 : Stainless steel faceplate fail secure W/Latch sensor
- 125102 : Stainless steel faceplate fail secure W/Latch sensor, keeper sensor

▼ SPECIFICATION

- Stainless steel face plate : 124L*32W*2.0T mm
- Door Latch : 1/2" (12.7mm)
- Keeper Depth : 11mm
- Voltage : 12 / 24V DC/AC (Selectable)
- Current Draw : 280mA / 12VDC
140mA / 24VDC

▼ FEATURE

- Fail secure/Fail safe reversible

▼ APPLICATION

